

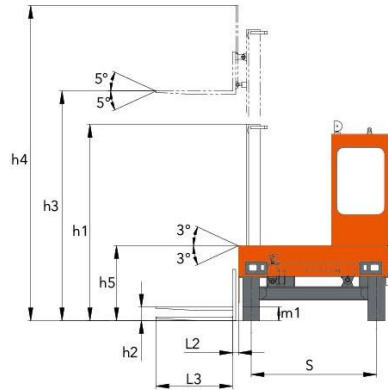

H SERIES  
SIDE-LOADING TRUCK **3-6 ton**

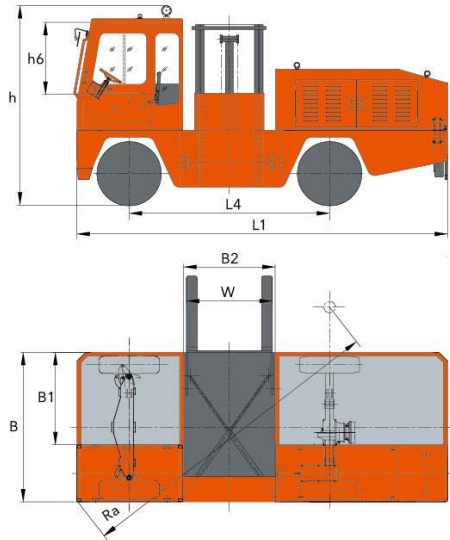

Mast											
Mast Model	Lifting Height (mm)	Capacity (kg)			Overall Height Mast lowered (mm)		Overall Height Mast Raised (mm)		Mast Tilting Angle(°)	Service Weight (kg)	
		CCCD30	CCCD50	CCCD60	CCCD30	CCCD50/CCCD60	CCCD30	CCCD50/CCCD60		CCCD30	CCCD50/CCCD60
M300	3000	3000	5000	6000	2178	2450	4082	4122	5-5	4800	8415
M330	3300	3000	5000	6000	2328	2600	4382	4422	5-5	4825	8450
M360	3600	3000	5000	6000	2478	2750	4682	4722	5-5	4850	8500
M400	4000	3000	5000	6000	2678	2950	5082	5122	5-5	4885	8570
M450	4500	2600	4400	5200	2928	3200	5582	5622	5-5	4930	8810
M485	4850	2400	4200	4800	3103	3375	5932	5972	5-5	4957	8880
M500	5000	2350	3500	4200	3178	3450	6082	6122	5-5	4977	8910
M530	5300	2200	3200	3800	3328	3600	6382	6422	5-5	5005	8970
M550	5500	2100	3000	3600	3428	3700	6582	6622	5-5	5020	9010
M600	6000	1900	2000	2400	3678	3950	7082	7122	5-5	5067	9120



**HELI** 安徽合力股份有限公司  
ANHUI HELI CO., LTD.  
ADD: NO.688 Fangxing Street, Economical Development Zone, Hefei, P.R.China  
TEL: (86 551) 63639068, 63639258, 63639358, 63662105  
FAX: (86 551) 63639966  
WEBSITE: <http://www.helichina.net>

**ĐẠI LÝ CHÍNH HÃNG XE NÂNG HÀNG HELI**  
**CÔNG TY TNHH XE NÂNG BÌNH MINH**  
Hotline: 097.790.3839  
Website: [xenangheli.com](http://xenangheli.com)  
Email: [hoangnguyen3888@gmail.com](mailto:hoangnguyen3888@gmail.com)

\* Our products are subject to improvements and changes without notice.

**3-6 ton**  
H SERIES  
SIDE-LOADING TRUCK



**HELI**  
LIFTING THE FUTURE

**24 YEARS** TOP1 FORKLIFT MANUFACTURER AND SALER IN CHINA FOR CONSECUTIVE 24 YEARS



H SERIES  
SIDE-LOADING TRUCK

**3-6 ton**



ISO9001  
ISO9001 Certification

CE  
CE Certification

## THE ADVANTAGE OF INTERNAL COMBUSTION SIDE-LOADING TRUCKS

- 1. Reliable and various engines**  
There are different engines available for different customers.
- 2. Leading performance parameter**  
Lifting speed, stretching speed and moving speed are higher than other domestic counterparts. Load center is 600mm which is the same as those forklifts in the advanced countries. Its loading capability is superior to those domestic forklift trucks.
- 3. Reasonable roller arrangement**  
The roller arrangement directly affects the work reliability and the life of the mast when the lifting system moves and stretches in the well-type passage. Cross arrangement of lengthways roller and side roller meet the needs of the work condition and extend the service life of the mast.
- 4. Deck and fork can tilt**  
Fork can tilt 5° up or down to load and unloads of the forklift truck.  
Deck can tilt 3° up or down so that the forklift truck is safer in shipping and more time- saving in unloadings.
- 5. Shock design**  
The front / rear axle is connected by articulated axle with the forklift frame at one end. The other end is a floating connection with the deck tilting cylinder. So, on an uneven road the front and rear wheels can float freely with the hydraulic automatic adjustment.
- 6. Hydraulic safety lock**  
The hydraulic locks are installed at supporting leg oil cylinder and interlocking oil cylinder for safe operation and for automatic lock of shift gear caused by the backpressure of hydraulic system.

### Parameter of engines

Forklift Model		CCCD30-W1	CCCD50/60-CU1
Engine model		ISUZU 4JG2	Cummins B3.3-C80
Rated power	kw/rpm	44.9/2450	60/2200
Rated torque	Nm/rpm	186/1600	291/1600
Engine displacement	L	3.059	3.3

### Manufacturer and technical parameters

Character			
1.01	Manufacturer	HELI	HELI
1.02	Model	CCCD30	CCCD50/60
1.03	Engine type	Diesel	Diesel
1.04	Capacity	kg 3000	5000/6000
1.05	Load center	mm 600	600
1.06	Operation type	Seated	Seated
Dimension			
2.01	Lifting Height	h3 mm 3600	3600
2.02	Mast overall height fork raised	h4 mm 4682	4722
2.03	Mast overall height fork lowered	h1 mm 2478	2750
2.04	Free lift	h2 mm 260	290
2.05	Cab overall height with lamp bracket	h mm 2710	2800
	Cab overall height without lamp bracket		2495
2.06	Distance from seat to cab roof	h6 mm 1020	960
2.07	Deck height	h5 mm 910	1050
2.08	Overall length	L1 mm 4290	5180
2.09	Fork overhang	L2 mm 75	100
2.10	Fork length	L3 mm 1150	1220
2.11	Wheelbase	L4 mm 2550	2800
2.12	Minimum clearance	m1 mm 180	190
2.13	Chassis width	B mm 1950	2100
2.14	Deck width	B1 mm 1200	1300
2.15	Forks external adjustable range (Max./Min.)	W mm 1070/290	1200/300
2.16	Mast apartment width	B2 mm 1140	1280
2.17	Tread	S mm 1600	1750
2.18	Minimum turning radius	Ra mm 4200	4730
2.19	Fork tilt (up/down)	5°/5°	5°/5°
2.20	Deck tilt (up/down)	3°/3°	3°/3°
Performance			
3.01	Max. traveling speed	km/h 18	24
3.02	Lifting speed (loaded)	mm/s 300	320
3.03	Lowering speed (loaded/unloaded)	mm/s ≤600/≥300	≤600/≥300
3.04	Mast moving speed (loaded)	mm/s 330	330
3.05	Gradeability with load	% 20	21
Weight			
4.01	Service weight	kg 4850	8500
4.02	Weight distribution loaded (front/rear)	kg 3680/4170	6280/7220(5t); 6780/7720(6t)
4.03	Weight distribution unloaded (front/rear)	kg 2180/2670	3780/4720
Tire			
5.01	Wheel number, X=driving wheel (front/rear)	2/2X	2/2X
5.02	Tire type	Pneumatic	Pneumatic
5.03	Tire size	7.00-15-12PR	9.00-16-14PR
5.04	Service brake	Hydraulic power brake-foot pedal	Hydraulic power brake-foot pedal
5.05	Parking brake	Mechanical -hand lever	Mechanical -hand lever
Transmission			
6.01	Transmission type	Hydroelectric power shift	Hydroelectric power shift
6.02	Shift gear (forward/backward)	I/I	I/I/I
Others			
7.01	Hydraulic system pressure	Mpa 20	25
7.02	Battery (system voltage/battery capacity)	V/Ah 12/120	24/80X2
7.03	Hydraulic tank capacity	L 60	90
7.04	Fuel tank capacity	L 60	90